

PRODUCT SPECIFICATION FOR INFORMATION

- Product Name : CERAMIC BAND PASS FILTER
- Part No : HD34242

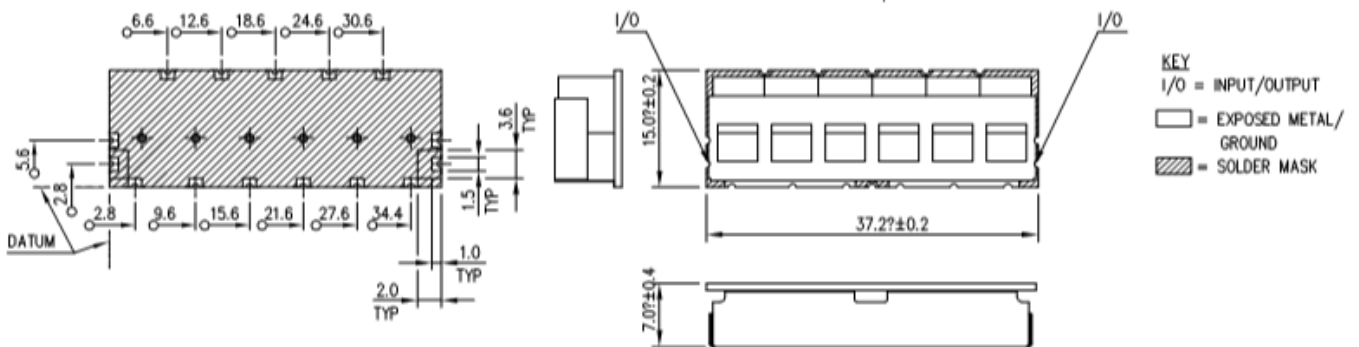

1. Center Frequency : 1200MHz
2. Bandwidth : 10MHz(1195 ~ 1205MHz)
3. Insertion Loss : 8.0dB Max
4. Ripple : 1.2dB Max.
5. Return Loss : 12dB Min.
6. Rejection : 44dB @ 1180 & 1220MHz
7. Impedance : 50Ω
8. Input Power rating : +30dBm Max.
9. Operating Temperature Range : -40 ~ +85°C
10. Size : 38 X 16 X 7.5mm Max.

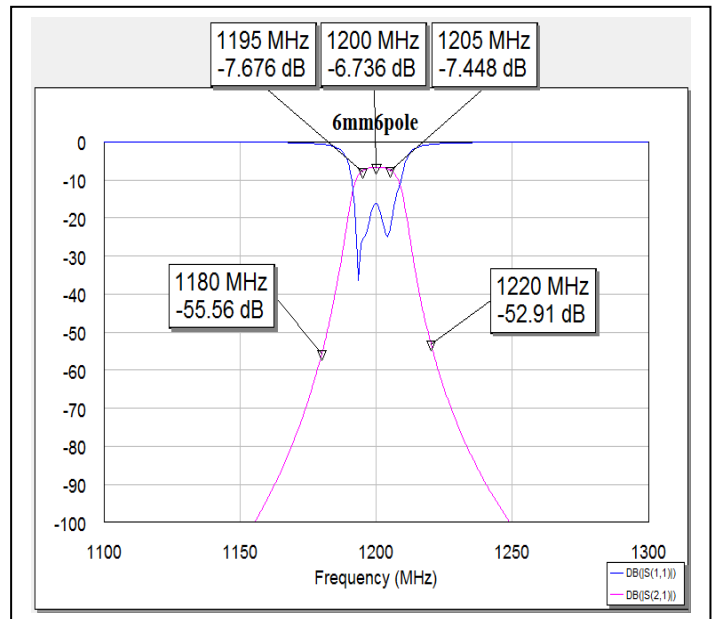

[SIMULATION PLOT]